

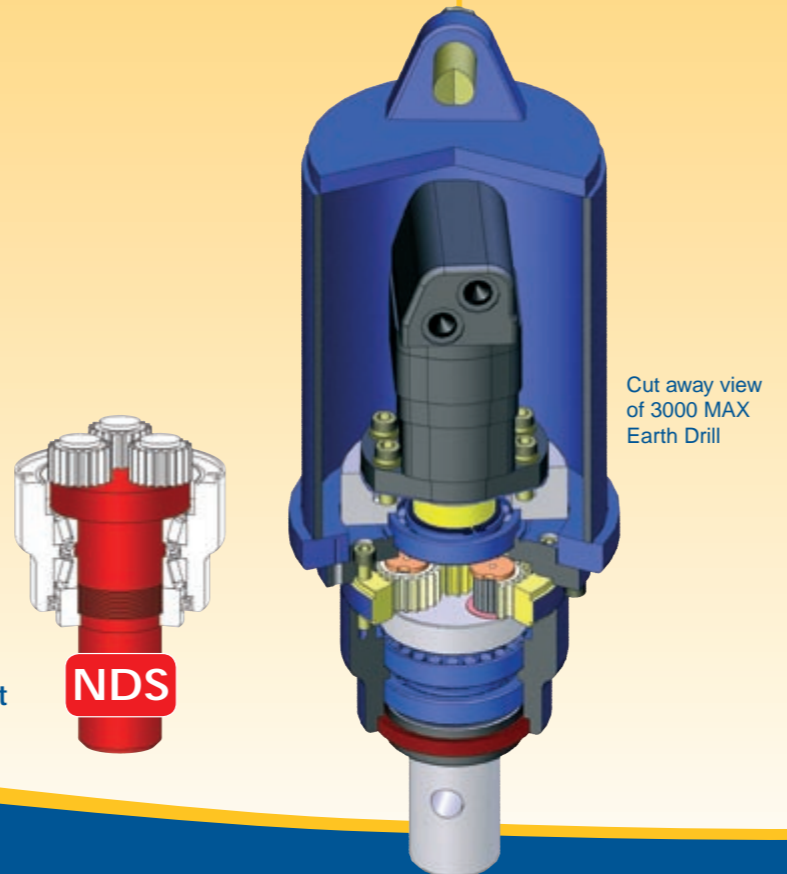

## Mini Excavators 1.2T to 5T

# Mini Excavators 1.2T to 5T

Earth Drill Models	X2000	X2500	3000 MAX	4000 MAX
Part Number	21-20100	21-20200	21-20500	21-30100
Excavator Machine Weight	1.2T to 2.5T	1.5 to 3T	2.5T to 4.5T	3T to 5T
Torque	1886 Nm	2452 Nm	3422 Nm	4510 Nm
Pressure	205 Bar	205 Bar	240 Bar	240 Bar
Oil Flow Range	25 to 57 l/m	27 to 65 l/m	40 to 95 l/m	50 to 95 l/m
Hydraulic Hoses	1/2" BSP	1/2" BSP	1/2" BSP	1/2" BSP
Output Shaft (STD)	65mm Rnd	65mm Rnd	65mm Rnd	65mm Rnd
Output Shaft (Optional)	2" Hex	2" Hex	2" Hex	2" Hex
Unit Weight	54kg	54kg	60kg	66kg
Unit Height	595mm	595mm	665mm	700mm
Unit Diameter	200mm	200mm	238mm	238mm
Auger Series	S4	S4	S4	S4
Length	1.2M	1.2M	1.2M	1.2M
Auger Diameter Range	100-400mm	100-500mm	100-600mm	100-750mm

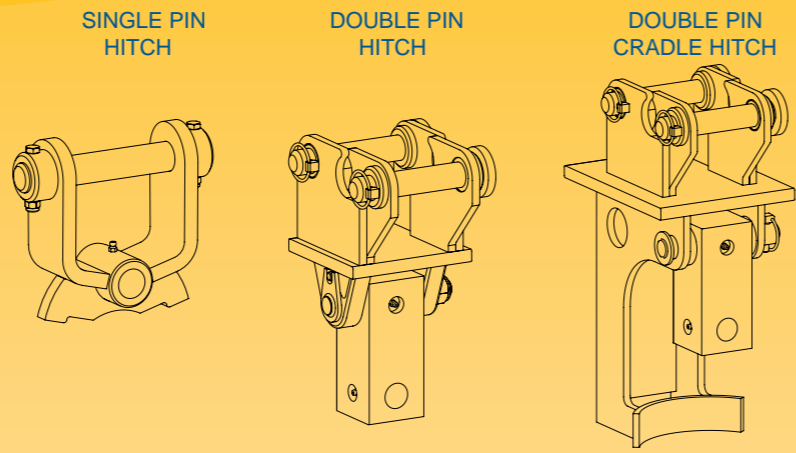

UNIQUE FEATURE  
Non Dislodgement Shaft

NDS

Mini Excavator 1.2T to 2.5T  
Drilling Diameter  
100 to 400mm

**X2000  
Earth Drill**

Mini Excavator 1.5T to 3T  
Drilling Diameter  
100 to 500mm

**X2500  
Earth Drill**

Mini Excavator 2.5T to 4.5T  
Drilling Diameter  
100 to 600mm

**3000 MAX  
Earth Drill**

Mini Excavator 3T to 5T  
Drilling Diameter  
100 to 750mm

**4000 MAX  
Earth Drill**



## Mounting Hitch Options

Pin Size	Single Pin Part Number	Double Pin Part Number	Double Pin Cradle Part Number
25mm	11-302500	12-302500	13-302500
30mm	11-303000	12-303000	13-303000
32mm	11-303200	12-303200	13-303200
35mm	11-303500	12-303500	13-303500
38mm	11-303800	12-303800	13-303800
40mm	11-304000	12-304000	13-304000

## S4 Extension Shafts - 65mm Round Drive

Length	500mm	800mm	1M
Part Number	31-4050200	31-4080200	31-4100200



Patent Applied Shock Loc<sup>RM</sup>

Solid Locking Pin

Shock Absorbing Element

S4 Auger Range - 65mm Round Drive (Length 1.2M) for X2000 - X2500 - 2500 - 3000 - 3000TC - 3000 MAX - 4000 - 4000 MAX Earth Drills

### Earth and Clay Drilling (Complete with Earth Teeth and Earth Pilot)

Diameter	100mm	150mm	200mm	225mm	250mm	300mm	350mm	400mm	450mm	500mm	600mm	750mm
Part Number	30-40101200	30-40151200	30-40201200	30-40231200	30-40251200	30-40301200	30-40351200	30-40401200	30-40451200	30-40501200	30-40601200	30-40751200

### Abrasive Drilling (Complete with Tungsten Teeth and Tungsten Pilot)

Diameter	100m	150mm	200mm	225mm	250mm	300mm	350mm	400mm	450mm	500mm	600mm	750mm
Part Number	30-40105200	30-40155200	30-40205200	30-40235200	30-40255200	30-40305200	30-40355200	30-40405200	30-40455200	30-40505200	30-40605200	30-40755200

### Hard/Abrasive Drilling (Complete with Tungsten Teeth and Extra Dig Pilot)

Diameter	100m	150mm	200mm	225mm	250mm	300mm	350mm	400mm	450mm	500mm	600mm	750mm
Part Number	30-40106200	30-40156200	30-40206200	30-40236200	30-40256200	30-40306200	30-40356200	30-40406200	30-40456200	30-40506200	30-40606200	30-40756200